



Vegetable Slicer TR210 Vegetable Slicer with Automatic Hopper - 2 Speeds

ITEM # _____

MODEL # _____

NAME # _____

SIS # _____

AIA # _____



Vegetable Slicer

TR210 Vegetable Slicer with Automatic Hopper - 2 Speeds

600081 (DTR2101V3)

Vegetable slicer, automatic hopper, 2 speeds 340-680 rpm.

Short Form Specification

Item No.

For small and medium catering facilities, up to 1000 meals per service, specially designed for cuts of vegetables such as grated carrot, celery, sliced potatoes and carrots in sticks of 3 or 4 mm. Stainless steel automatic feed hopper with an aluminium base allows large scale preparation (up to 2100 kg/h). 2 speeds cutter (340 rpm). "No volt release" safety device. Self-braking motor. On/off switch on the body of the machine. Table top version. Standard lever-operated hopper and long vegetable hopper available upon request.

Main Features

- Suitable for 100-800 meals for table service and up to 1000 meals for catering service.
- Vegetable slicer unit has slicing, grating, shredding (julienne) as well as dicing and french fries capabilities.
- Delivered with:
 - automatic hopper
 - cutting chamber
 - ejector disc
- Continuous feed model, hopper capacity is 5/6 kg.
- All parts in contact with food are removable without the use of tools, stainless steel hopper, stainless steel lever and cutting chamber are dishwasher safe.
- Complete and wide selection of blades and grids available (diam. 205 mm).
- High flexibility and ergonomony thanks to the available optional accessories.
- Smart design trolley to place the unit and the 2/1 GN tray to collect cut veggies, to maximize productivity and grant effortless operation (optional).
- Long vegetable hopper (4 round hoppers with different size) available as optional accessory to better fit different type of vegetables/fruits.
- Lever operated hopper (including long vegetable and half moon hoppers) to reach the maximum precision in the result (optional).

Construction

- All discs (available on request) are made in stainless steel and dishwasher safe.
- Automatic hopper are made entirely in stainless steel for better durability.
- Long vegetable hopper, lever operated hopper and the smart trolley are made in stainless steel.
- Aluminum alloy motor housing, to improve motor ventilation without creating openings in the motor base frame.
- Power: 750 watts.
- 2 speeds: 340-680 rpm.
- Asynchronous silent industrial motor for heavy duty and longer life.
- Water protected planetary system (IP55 electrical controls, IP23 overall machine).

Included Accessories

- 1 of Ejector disc PNC 653772

Optional Accessories

- Stainless steel long vegetable hopper with 4 tubes different sizes with pusher (no cutting chamber, no ejector) for TR210 PNC 650063
- Stainless steel lever-operated hopper for TR210 (no cutting chamber, no ejector) PNC 650064
- Stainless steel trolley for 2/1GN trays (GN tray not included) PNC 650065
- Stainless steel shredding disc with S-blades 4x4 mm PNC 650077
- Stainless steel shredding disc with S-blades 6x6 mm (can also be used for French fries) PNC 650078

APPROVAL: _____





Vegetable Slicer TR210 Vegetable Slicer with Automatic Hopper - 2 Speeds

- Stainless steel shredding disc with S-blades 8x8 mm (can also be used for French fries) PNC 650079
- Stainless steel shredding disc with S-blades 10x10 mm (can also be used for French fries) PNC 650080
- Stainless steel pressing/slicing disc with S-blades 0,6 mm (can be used for slicing or combined with grids) PNC 650081
- Stainless steel pressing/slicing disc with S-blades 1 mm (can be used for slicing or combined with grids) PNC 650082
- Stainless steel pressing/slicing disc with S-blades 2 mm (can be used for slicing or combined with grids) PNC 650083
- Stainless steel pressing/slicing disc with S-blades 3 mm (can be used for slicing or combined with grids) PNC 650084
- Stainless steel pressing/slicing disc with S-blades 4 mm (can be used for slicing or combined with grids) PNC 650085
- Stainless steel pressing/slicing disc with S-blades 5 mm (can be used for slicing or combined with grids) PNC 650086
- Stainless steel pressing/slicing disc with S-blades 6 mm (can be used for slicing or combined with grids) PNC 650087
- Stainless steel pressing/slicing disc with S-blades 6 mm (can be used for slicing or combined with grids) PNC 650088
- Stainless steel pressing/slicing disc with corrugated S-blades 2 mm (can be used for slicing or combined with grids) PNC 650089
- Stainless steel pressing/slicing disc with corrugated S-blades 3 mm (can be used for slicing or combined with grids) PNC 650090
- Stainless steel pressing/slicing disc with corrugated S-blades 6 mm (can be used for slicing or combined with grids) PNC 650091
- Bistrot Pack-set stainless steel discs (2mm and 5mm slicing pressing disc, 2mm grating disc) PNC 650092
- Gastronomy Pack-set stainless steel discs (2mm, 5mm and 10mm slicing pressing discs, 2mm grating disc, 4x4mm shredding disc, 10x10mm dicing grid) PNC 650093
- Stainless steel shredding disc with S-blades 2x8 mm PNC 650158
- Stainless steel shredding disc with S-blades 2x10 mm PNC 650159
- Stainless steel pressing/slicing disc with S-blades 10 mm (can be used for slicing or combined with grids) PNC 650160
- Stainless steel pressing/slicing disc with S-blades 12 mm (can be used for slicing or combined with grids) PNC 650161
- Stainless steel pressing/slicing disc with corrugated S-blades 8 mm (can be used for slicing or combined with grids) PNC 650162
- Stainless steel pressing/slicing disc with corrugated S-blades 10 mm (can be used for slicing or combined with grids) PNC 650164
- Stainless steel pressing/slicing disc with S-blades 13 mm (can be used for slicing or combined with grids) PNC 650165
- Stainless steel shredding disc with S-blades 2x2 mm PNC 650166
- Stainless steel shredding disc with S-blades 3x3 mm PNC 650167
- Set of 4 stainless steel discs (2mm and 5mm slicing pressing discs, 2mm and 7mm grating discs) PNC 650178
- Set of 7 stainless steel discs (2mm, 5mm and 10mm slicing pressing discs, 2mm and 7mm grating discs, 4x4mm shredding disc, 10x10mm dicing grid) PNC 650179
- Dicing grid 5x5 mm PNC 653566
- Dicing grid 8x8 mm PNC 653567
- Dicing grid 10x10 mm PNC 653568
- Dicing grid 12x12 mm PNC 653569
- Dicing grid 20x20 mm PNC 653570
- Grid for chips 6x6 mm PNC 653571
- Grid for chips 8x8 mm PNC 653572
- Grid for chips 10x10 mm PNC 653573
- Ejector disc PNC 653772
- Stainless steel grating disc 2 mm PNC 653773
- Stainless steel grating disc 3 mm PNC 653774
- Stainless steel grating disc 4 mm PNC 653775
- Stainless steel grating disc 7 mm PNC 653776
- Stainless steel grating disc 9 mm PNC 653777



Vegetable Slicer TR210 Vegetable Slicer with Automatic Hopper - 2 Speeds

The company reserves the right to make modifications to the products without prior notice. All information correct at time of printing.



Vegetable Slicer TR210 Vegetable Slicer with Automatic Hopper - 2 Speeds

Front

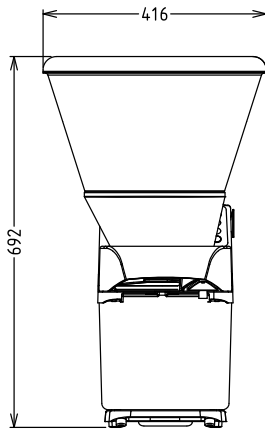

Top

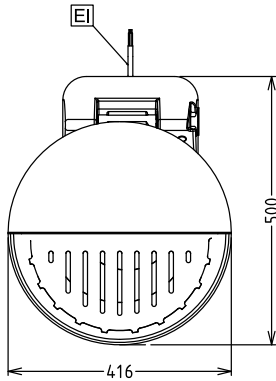

EI = Electrical inlet (power)

Side

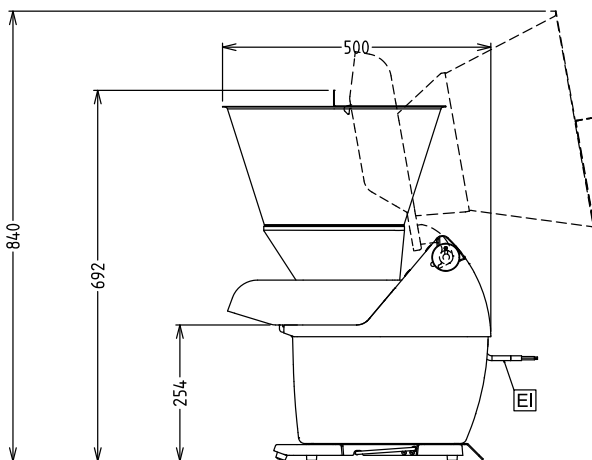

Electric

Supply voltage:

600081 (DTR2101V3) 380-440 V/3 ph/50/60 Hz

Electrical power max.: 0.75 kW

Total Watts: 0.75 kW

Capacity:

Performance (up to): 2100 - kg/hour

Key Information:

External dimensions, Height: 690 mm

External dimensions, Width: 416 mm

External dimensions, Depth: 490 mm

Shipping weight: 34.7 kg



Vegetable Slicer
TR210 Vegetable Slicer with Automatic Hopper - 2 Speeds

The company reserves the right to make modifications to the products without prior notice. All information correct at time of printing.