



# Food Processor Cutter Mixer 3.5 LT - Single Speed

ITEM # \_\_\_\_\_

MODEL # \_\_\_\_\_

NAME # \_\_\_\_\_

SIS # \_\_\_\_\_

AIA # \_\_\_\_\_



## Food Processor

### Cutter Mixer 3.5 LT - Single Speed

603825 (DK35Y)

Cutter mixer 3,5 lt capacity, 1 speed 1500 rpm. Supplied with finely toothed blade rotor and stainless steel bowl

## Short Form Specification

### Item No.

Robust cutter for liquidising, mixing and mincing in a matter of seconds. AISI 302 stainless steel 3,5 litre bowl. Lid incorporates opening to add ingredients in mid-cycle. Transparent cover incorporates a magnetic contact safety system. Finely toothed blade rotor. Angled blades and conical base of the bowl ensure consistent mixing. Parts in contact with food are removable and dw safe. 1 speed rotor: 1500 rpm.

## Main Features

- Robust cutter allows fast liquidizing, mixing, mincing and chopping.
- Angled blades and conical base of the bowl ensure consistent mixing.
- Lid with central opening to add ingredients in mid-cycle.
- Delivered with:  
- 3,5 lt stainless steel bowl with finely toothed blades rotor
- Parts in contact with food are removable and dishwasher safe.
- Pulse function to coarse chopping.
- Productivity suitable for 10-50 meals per service.

## Construction

- 302 AISI stainless steel bowl is positioned on the central shaft. Bowl supplied with a leak resistant spout.
- Speed motor: 1.500 rpm.
- Transparent lid incorporates a magnetic contact safety system.

## Included Accessories

- 1 of Finely toothed blade rotor for 3,5 ltPNC 653028 cutter mixer
- 1 of Stainless steel bowl for 3,5 lt PNC 653096 cutter mixer

## Optional Accessories

- Finely toothed blade rotor for 3,5 lt PNC 653028 cutter mixer
- Smooth blade rotor for 3,5 lt cutter PNC 653029 mixer
- Stainless steel bowl for 3,5 lt cutter PNC 653096 mixer

APPROVAL: \_\_\_\_\_





# Food Processor Cutter Mixer 3.5 LT - Single Speed

**Front**

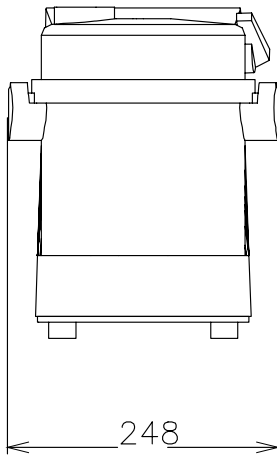

**Top**

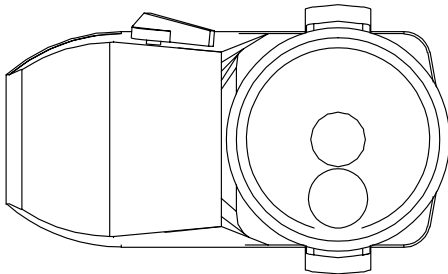

EI = Electrical connection

**Side**

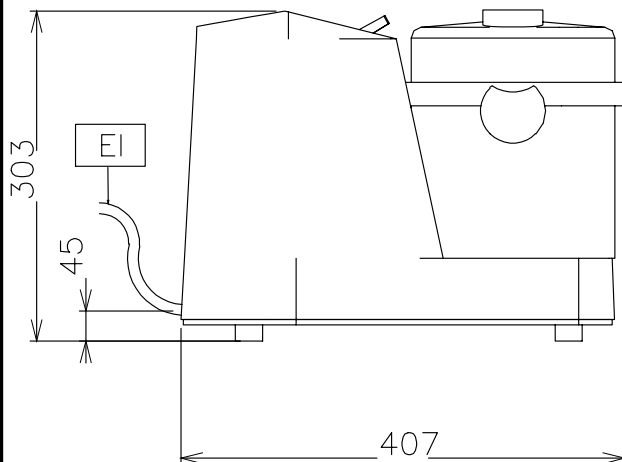

## Electric

Supply voltage:	220-240 V/1N ph/50 Hz
603825 (DK35Y)	
Electrical power max.:	0.5 kW
Total Watts:	0.5 kW

## Capacity:

Performance (up to):	1.8 - kg/Cycle
Capacity:	3.5 liter

## Key Information:

External dimensions, Height:	303 mm
External dimensions, Width:	247 mm
External dimensions, Depth:	407 mm
Shipping weight:	17 kg

**Food Processor  
Cutter Mixer 3.5 LT - Single Speed**

The company reserves the right to make modifications to the products without prior notice. All information correct at time of printing.

