



Franke | Flair

## Technical Specification & Requirements

**Height:** 523mm (including hopper)

**Width:** 423mm

**Depth:** 542 (including drip tray)

**Weight:** 66kg (when full)

**Power:** Standard 3 pin plug - 230V, 1LNPE, 2.3kW, 10A

**Water:** Unplumbed 5.5L side water tank

**Waste:** Unplumbed residual water tray with monitoring

Milk cooler available, please discuss with one of our sales team.  
In some areas of the UK, hard water can damage your machine.  
To limit this, we provide a free Claris Filter unit with your machine  
under the service rental contract. Replacement cartridges for the  
Claris Filter unit can be purchased from Matthew Algie.

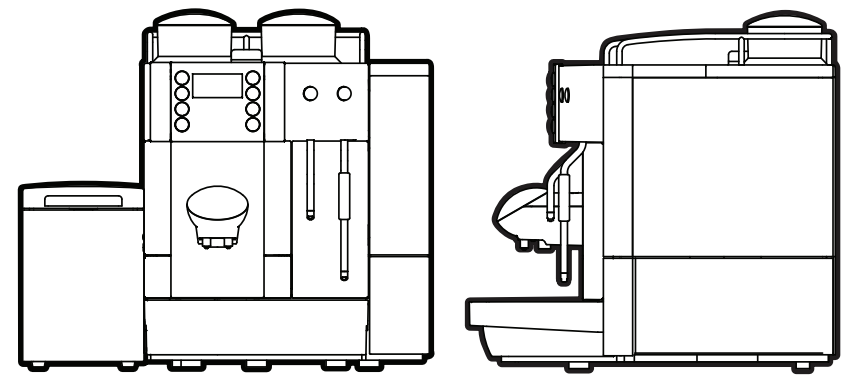

# Franke

## Flair

**Raise the standard of your coffee offering at the press of a button.**

Small and perfectly formed with all the premium and quality values associated with espresso coffee in a small footprint machine. Two grinders for different roasts, up to eight different pre-programmed coffee styles, steam wand for hand-foaming milk and a hot water tap for tea.

The Flair does all the work so you don't have to.



## Features & Benefits

- **Compact fully automatic bean to cup technology delivers quality and consistency**
- **Beans freshly ground for every cup**
- **Perfect coffee solutions for bars, offices and small cafes serving up to 100 cups per day**
- **Visually attractive and easy to use, ideal for front-of-house**
- **Fully portable - no plumbing required**
- **Steam wand to hand foam milk for lattes and cappuccinos**
- **Control panel alerts user to refilling, emptying and cleaning requirements**

If your business requires fresh quality coffee presented consistently throughout the day, regardless of who's preparing it, then the Flair is a great solution. With its small footprint and no requirement to be plumbed in, it can be conveniently located almost anywhere.

