

Model: CNB

Technical features

| Reference | Utility | Total dimensions (mm) | Objects dimensions (mm) |
|-----------|---------|-----------------------|-------------------------|
| 19005438 | Trays | 560 x 640 x 915 | 530 x 370 (maximum) |

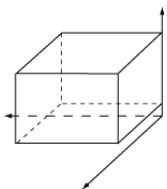
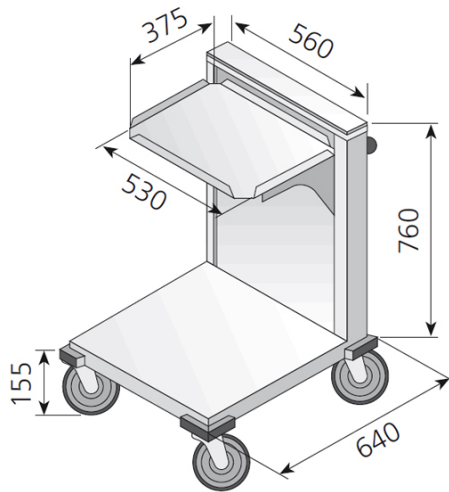

Packaging dimensions:

Depth: 640,000 MM

Width: 665,000 MM

Height: 965,000 MM

Gross weight: 49,000 KG

General features

Especially designed for storing and transporting trays and dish baskets.

Entirely made of stainless steel.

First-class, robust spring system keeping the trays or baskets at a constant level for the user.

Four (4) castors of 125 mm diameter, two (2) of them with brakes for safer use.

Non-marking, special rubber bumpers to protect against direct impacts in all four (4) corners.

Cutlery container on top of CNB-C model included.

Estimated capacity:

Trays: CNB, CNB-C

Up to 120 standard trays 530 x 370, 480 x 370, 450 x 370 mm.

Up to 120 GN 1/1 trays 530 x 325 mm.

Up to 200 fast-food trays 350 x 270 mm.

Dishwashing baskets: CNC

Up to 6 baskets 500 x 500 mm, with a height of 110 mm.





Self-levelling cart for trays.

Self-levelling cart for trays and cutlery, including cutlery container

Self-levelling cart for dishwashing baskets.

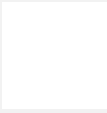

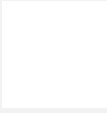
Spare parts

| Reference | SAP reference | Description | Recommended | Replaced | Price |
|---|---------------|-------------|--|----------|----------|
| C109010007 | 12033369 | CNB-C TRAY | | | 0.00 EUR |
|  | 6005010001 | 12037077 | CORNER OF 3120X150X15 MM. | | 0.00 EUR |
| | 6033090016 | 12036360 | SPRING.TRACTION.L-150X25EXT.2H INOX N1 | ✓ | 0.00 EUR |
|  | 6003010002 | 12044928 | BUMPER 90° GREY | | 0.00 EUR |
|  | 6033130009 | 12033956 | WHEEL WITH BRAKE D125 (77X67) | | 0.00 EUR |
|  | 6033130013 | 12034570 | WHEEL WITHOUT BRAKE D125-PLAT.77X67 | ✓ | 0.00 EUR |
|  | 6003010094 | 12037118 | HOT VEHICLES HANDLE SUPPORT (BLUE) | ✓ | 0.00 EUR |
|  | 6025050034 | 12050254 | SCREW M10X40 ALLEN DIN 912 | | 0.00 EUR |
| | 6025130002 | 12037889 | TUERCA ZIN M10 | | 0.00 EUR |