

Product Name	ThermaCube™ Delivery System Induction Charger	Quantity		Item #	
--------------	--	----------	--	--------	--



Bag and pellet cage assembly sold separately. Standard bag is black.

Note: For use with CookTek® TCS System specific heated delivery bags and pellet cage assemblies only.



Agency listings for chargers only. Bags and pellet cage assemblies not listed.

Standard Features

- Portable table top design with powder coated steel, heavy duty electronic components, and high impact polycarbonate locator
- Microprocessor monitors vital components multiple times per second to check for overheating, power supply problems and more. Charger shuts off and indicates error codes enabling user to diagnose and correct minor problems
- Initial charge in four minutes or less
- Recharge in 60 seconds (avg.)
- Lightweight pellet and bag
- Manufactured and designed for easy installation and use - no cord to the bag, no heating element maintenance, and no extra labor steps
- Manufactured and designed to operate on a standard countertop or "dropped-in" to a custom shelving unit
- Heat energy is generated and contained in a pellet located in the delivery bag. The charger surface does not get hot.
- User friendly control panel and LED lighted displays are easy to understand and simple to operate
- Charger manufactured and designed to handle exposure to flour, dust, oil, grease, and various other food substances found in food establishments
- Automatic load detection allows for instant energy transmission to bag, and almost no energy consumption when bag is not present
- Automatic shut-off feature prohibits overheating

- Easy to clean polycarbonate surface
- Integral cooling fan keeps internal electronics cool
- Available in 100-120VAC or 200-240VAC
- **240VAC unit not available in US/Canada**
- Three year limited warranty in US and Canada only - see statement for details.
- Made in the USA*

Specifications

Shall be a CookTek® induction thermal delivery system, model _____ with a total kW rating of _____.

Unit shall be fabricated with a powder-coated steel housing, polycarbonate locator tray and membrane control panel.

Unit shall be a high power induction heating system, intended for the rapid thermal charging of a special heat retaining pellet, correctly installed in a CookTek® approved insulated bag.

Unit shall operate on _____ power with integral _____ cord and plug (supplied).

NOTE: ThermaCube™ Thermal Delivery System must be used in conjunction with CookTek® approved TCL bags and TCL FlashPak™ pellet cage assemblies.

*of USA and imported parts

Global Operations
2801 Trade Center Drive
Carrollton, Texas 75007 USA
www.cooktek.com | www.turbochef.com

Phone: +1 800.908.8726
+1 214.379.6000
Fax: +1 214.340.6073

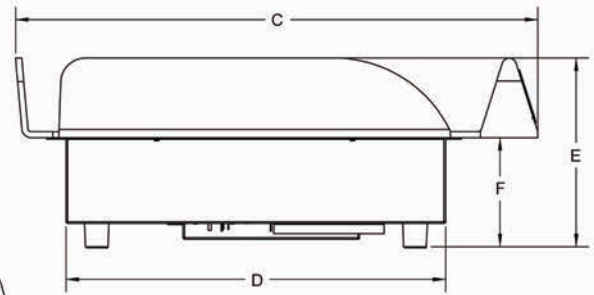
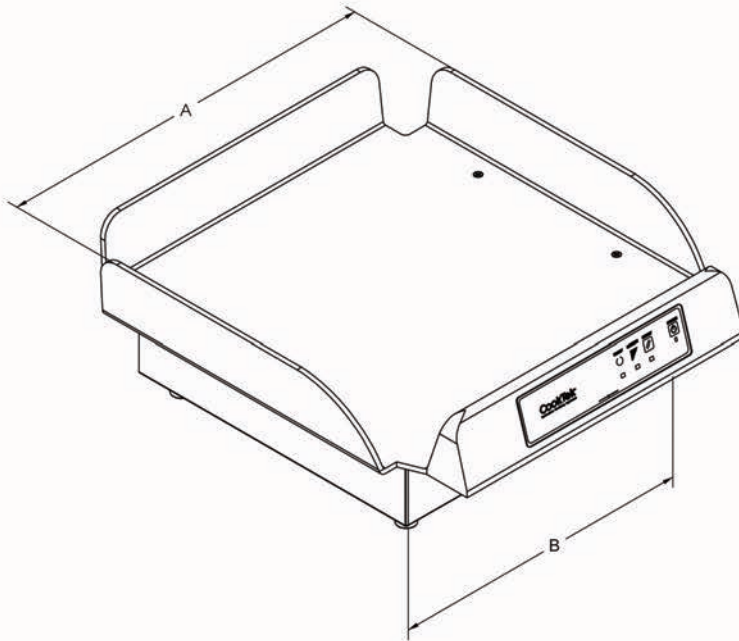

Dimensions		
	inches	mm
A	16.47	418
B	12.25	311
C	16.93	430
D	13.75	349
E	8.18	208
F	4.55	116



Agency listings for chargers only. Bags and pellet cage assemblies not listed.

- Dedicated circuit required
- Requires maximum (do not exceed) ambient temperature of 50°C/122°F
- Cooling clearance: 2" (55mm) for front and rear, 6" (152mm) below when mounted in custom shelving unit

Specifications

Model Number	TCS100	TCS200
Power Requirements	100-120VAC, 1Ph	200-240VAC, 1Ph
Power Consumption	1800W	1800W
Voltage	100-120VAC, 50/60 Hz	200-240VAC, 50/60 Hz
Amperage	15A (max)	8A (max)
Base Dimensions (in)	13.75" x 12.25" x 4.25"	13.75" x 12.25" x 4.25"
Base Dimensions (mm)	349 x 311 x 108	349 x 311 x 108
Dimensions w/bag locator (in)	16.47" x 16.93" x 8.18"	16.47" x 16.93" x 8.18"
Dimensions w/bag locator (mm)	418 x 430 x 208	418 x 430 x 208
Weight	14.5 lbs / 6.6 kg	14.5 lbs / 6.6 kg
Packaged Weight	19.25 lbs / 8.7 kg	19.25 lbs / 8.7 kg
Packaged Dimensions (in)	23" x 20" x 13"	23" x 20" x 13"
Packaged Dimensions (mm)	542 x 508 x 330	542 x 508 x 330
Power Cord Length	6 ft / 1.8 m	6 ft / 1.8 m
Plug Type	NEMA 5-15P	Country Specific
Warranty	36 month limited parts and labor (charger only)	contact distributor for warranty details

Note: Ambient air should not exceed 50°C/122°F. Dedicated circuit required. Many local codes exist, and it is the Owner and Installer's responsibility to comply with those codes. CookTek continually improves its products and reserves the right to change or improve specifications without notice.

Global Operations
2801 Trade Center Drive
Carrollton, Texas 75007 USA
www.cooktek.com | www.turbochef.com

Phone: +1 800.908.8726
+1 214.379.6000
Fax: +1 214.340.6073