



Popcorn Machine 8 Oz

“Anvil’s Popcorn Machines are perfect for producing and storing popcorn. Their attractive appearance means they are ideally suited to a “point of sale” environment. The units are designed to operate continuously.”



 ANVIL

AXIS

Model: PMK0001

APPLICATION

- Ideal for cafes, school tuck shops, take-aways and outside catering

CONSTRUCTION

- All Stainless Steel interior
- Toughened glass safety windows
- Removable bottom plate and tray for easy cleaning
- Non-stick coated kettle, with hinge down feature for easy loading and unloading
- Supplied with a serving scoop
- Large storage area for prepared popcorn

HEATING

- Warming light for product display
- Interior heater to keep product warm
- Powerful kettle element for rapid batch turn around times
- Illuminated control switches

SAFETY

- Kettle and heater elements fitted with individual preset temperature limiting switches



ALL ANVIL EQUIPMENT COMES WITH A ONE YEAR WARRANTY ON COMPONENTS AND DEFECTIVE WORKMANSHIP.
www.anvilworld.com

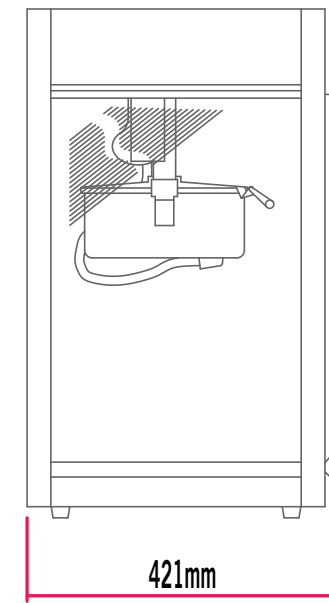
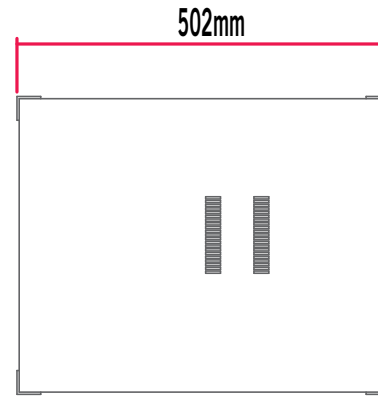
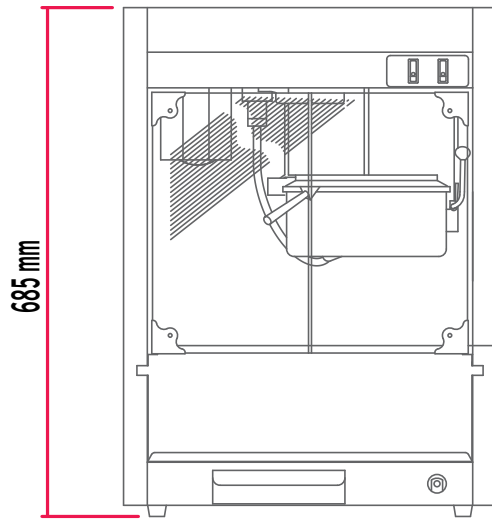

DESCRIPTION

MODEL
POWER RATING (230V/50Hz)
DIMENSIONS (mm) (W x D x H)
BOX DIMNS (mm) (W x D x H)
PACKED WEIGHT (kg)

- Unit available in 120V/60Hz configuration

POPCORN MACHINE 8 Oz

PMK0001
1.5kW
502 x 421 x 685
540 x 455 x 720
26

Model: PMK0001

NOTE: When viewing the appliance from the front in its usual operating position, the width (W) of the product is the total distance from left to right; the depth (D) of the product is the total distance from the front to the back; the height (H) is the total distance from the bottom of the product to the top.

 ANVIL

AXIS

Note: Output performance figures quoted are dependant on various factors

Anvil reserves the right, without notice, to make changes and revisions to product specifications, materials and design, which in our opinion, will provide better performance, durability and efficiency.