



Catalogue :

SERIE 900 KORE

Chapter :

FRYERS 900 KORE

Article :

F-G9121 LPG 230V 1N 50Hz 2C

Code:

19033852

<u>DIMENSIONS AND WEIGHTS</u>		<u>Net dimensions</u>	<u>Packed</u>
Length	mm	400,00	1.022,00
Depth	mm	930,00	440,00
Height	mm	850,00	1.115,00
Weight	kg	75,00	90,00
Volume	m3	0,36	0,50
<u>ELECTRICITY</u>		230V	50Hz
	Power		0,10 kW
Connections	230 V. 1+N+T	2X1,5+T - 2 A	
	230 V. III+T		
	400 V. III+N+T	4X4MM2+T	
<u>GAS</u>	Power		21,00 kW
	Gas type	LPG	
	Consumption		1,61 kg/h
	Pressure	LPG G30/G31 28-30/37 mbar	
<u>WATER</u>	Not necessary		
<u>STEAM</u>	Not necessary		
<u>AIR</u>	Not necessary		

DESCRIPTION

GAS DEEP FAT FRYER, F-G9121

Fryers are designed to deep fry large amounts of product (chips, croquettes, different types of dredgings, etc.).

2 mm stainless AISI-304 steel top with rounded edges for easy cleaning.

Laser cut and automatic welding for a perfect adjustment of sides between modules with square angle finish.

Number of wells: 1.

Well capacity: 21 litres.

Standard equipment: Two 132x338x132 mm baskets.

Well integrated in the top, with cool area at the bottom. This helps to maintain oil properties and quality for a longer time.

Highly efficient heat exchanger gas tubes integrated alongside the well. Electronic ignition.

Superior power/litre rate: 1.047 kW per litre.

Thermostat for temperature control (between 60 and 200°C).

Safety thermostat.

Oil discharge through robust and reliable high temperature resistant ball tap.

Fitted with independent lids for each well.

Basket drainage support at the back of the well.

Water-tight and protecting-support controls.

High temperature protector for the chimney made of enamelled cast iron.

Front access to components.

According to European standards for components and panels temperature, efficiencies and combustion, and sanitary regulations (EN-60335 and EN-203)

IPX5 grade water protection equipment.

Maximum power: 22.0 kW - Gas

It requires an 230V - 1+N power supply.

Dimensions: 400 x 930 x 850 mm.

SOUND LEVEL < **65,00** db

CERTIFICATES **1312CS6209**

INSTALLATION - CONNECTIONS Ø

- ▶ ELECTRICITY SI
- ▶ GAS "R,3/4""G"





Catalogue :

SERIE 900 KORE

Chapter :

FRYERS 900 KORE

Article :

F-G9121 LPG 230V 1N 50Hz 2C

Code :

19033852

SCHEMA - DIMENSIONS

F-G9115 & F-G9121

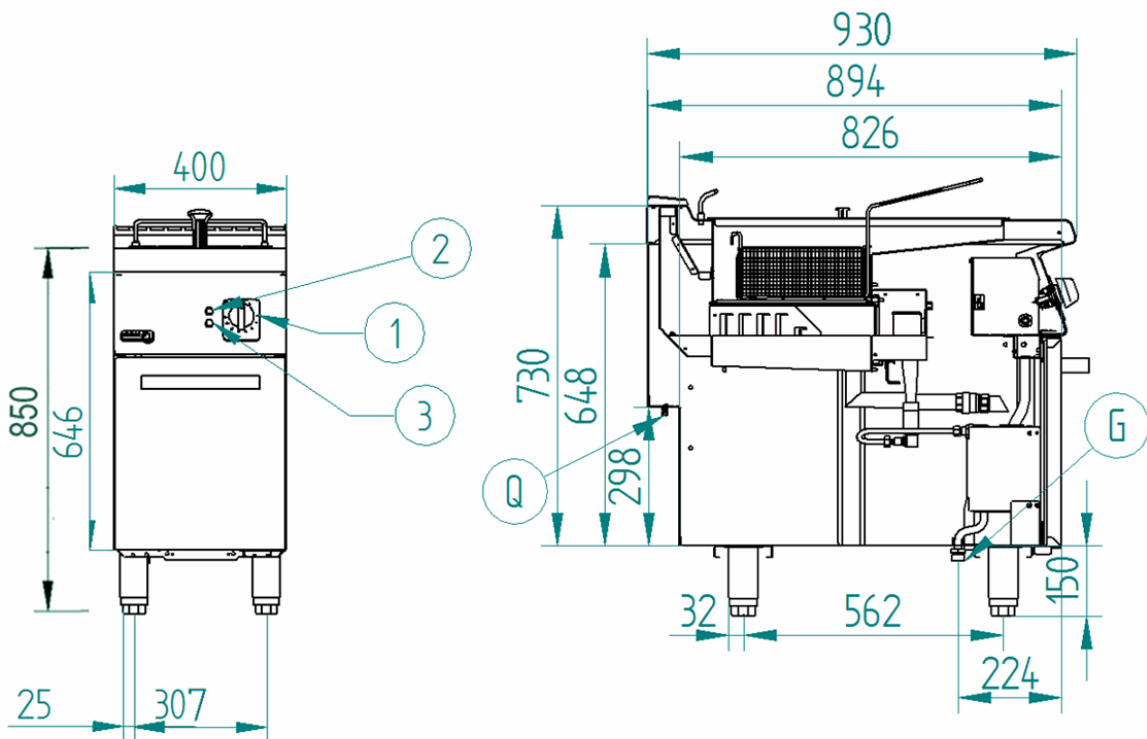

Q – Conexión equipotencial

G – Entrada de Gas

1 – Grifo válvula de gas

2 – Piloto verde

3 – Piloto ambar

Equipotential connection

Gas Inlet

Gas valve tap

Green pilot

Ambar pilot